

iCtP™

PlateWriter™ 3000

**MORE PRODUCTIVITY
MORE QUALITY
EVEN MORE VERSATILE**



Several years ago we launched our first iCtP PlateWriter systems. Now Glunz & Jensen is proud to introduce our latest generation of iCtP systems, the PlateWriter™ 3000.

By utilising recent advances in imaging technology the PlateWriter™ 3000 series builds on our critically acclaimed 2000/2400 series. The new PlateWriter™ carries forward our environmentally friendly approach to plate making, by delivering press ready aluminium plates without any use of chemical processing.

The PlateWriter™ 3000 is suitable for all 2up presses and many 4up presses with a maximum plate size of 619mm (24.4") x 914mm (36").

The PlateWriter™ 3000's semi-automated plate registration system also provides a versatile plate handling approach which means multiple plate sizes and gauges can be used with no changes.

In addition the sophisticated design of the PlateWriter™ 3000 delivers the highest productivity of all the PlateWriter series, making it suitable for higher volume users in comparison to the PlateWriter 2000/2400 series.

After imaging the plates are then fed through the integrated finishing unit that dries the plate and bonds the liquid dots to the plate surface.



The PlateWriter™ 3000 is powered by the industry standard Harlequin Postscript RIP. Accepting jobs from Mac or PC in Postscript, PDF, EPS, TIFF & JPEG formats - handling your job, ripping it and outputting it directly to the PlateWriter™



The PlateWriter™ 3000 features a semi-automated plate alignment system to ensure accurate registration and transport through the imaging engine.



The PlateWriter™ images in daylight and needs no processing chemistry as it uses advanced inkjet technology to add the image to your plate, eliminating any mess or fuss.



Easy to use - Imaging in front of your eyes on to non-photosensitive conventionally grained aluminium plates, the PlateWriter™ delivers a standard metal plate for your press room that requires no press room changes



Imaged plates are fed through the integrated Finishing Unit, located below the Print Engine. This finishes the plates by drying and bonding the liquid dots to the plate surface. The Finishing Unit includes a built-in gumming station to apply a protective gum layer.

GLUNZ & JENSEN 

PLATESETTING • ICTP

iCtP™ PlateWriter™ 3000

Technical specifications

Imaging device	10 x 360 Ultra high definition imaging array (3600 dual density nozzles delivering 2880dpi)
Imaging fluid	Patented Liquid Dot™ technology
Plate type	Uncoated grained and anodized aluminum plate, optimized for iCtP™ (All 1, 2-up formats and most 4-up formats)
Plate thickness	Aluminum 0.15 / 0.20 / 0.30 mm (0.006 / 0.008 / 0.012")
Plate width	210 - 619 mm (8.27 - 24.4")
Plate length	279 - 914 mm (11.0 - 36")
Max imaging size (W x L)	609 x 896 mm (24.0 x 35.26")
Plate finishing	Automated integral gumming system
Imaging resolution	1440 x 1440 / 1440x 2880 or 2800 x 2800 dpi
Imaging speed	10-20 B3 plates/hour @ max resolution Dependent on plate format and image coverage
Run length	50,000 impressions
RIP	Harlequin based RIP platform: 2GB RAM, 100 BaseT ethernet with connectivity to MAC and PC environments
Screening	Stochastic screening, optimized for iCtP™ ensuring moiré free prints
Power supply	100 to 230 VAC, 50/60 Hz
Power consumption	Stand by: 0.3 kW Process: 3 kW
Operating environment	Temperature range 15 - 32°C (59 - 90°F); 20°C (68°F) or higher recommended
Humidity range	35 to 80% (no condensation)
Footprint (L x W x H)	2284 x 1360 x 1446 mm (89.9 x 53.5 x 56.9")
Weight	Crated: 320 kg (705 lbs) Non crated: 215 kg (474 lbs)
Standard equipment	PlateWriter high definition Inkjet Print Engine, finishing unit including baking, gumming and dryer system, feed and delivery table, stand for PlateWriter 2400, RIP workstation with Mac and PC connectivity, Harlequin based Xitron RIP with iScreening technology, basic colour proofing support for Epson 4800/4880, 7800/7880, 9800/9880, and fluid start-up kit.

NB: This brochure was printed on a Heidelberg® Speedmaster with plates created on a PlateWriter™ system.

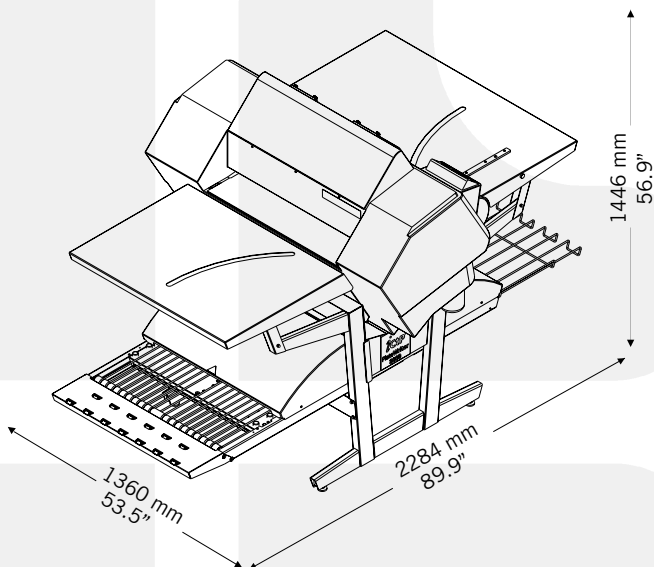

GLUNZ & JENSEN

Headquarters:
Glunz & Jensen A/S
Haslevvej 13
DK-4100 Ringsted
Denmark
Tel. +45 57 68 81 81
Fax +45 57 68 83 40
ictp@glunz-jensen.com

Glunz & Jensen, Inc.
12633 Industrial Drive
Granger, IN 46530
USA
Tel. +1 574 272 9950
Fax +1 574 277 6566
ictp@glunz-jensen.com

www.platewriter.com